

Anti-Vibration Leveling Mounts

Sorbothane® Anti-Vibration Leveling Mounts provide both leveling and vibration isolation. They are designed to handle a wide range of loads and varying environmental conditions. Major benefits of the mounts include their ability to isolate a system from unwanted vibration and resonance by lowering the natural frequency of the system.



The dual urethane compounds compliment each other to provide a high degree of vibration and shock damping. These mounts provide a quick, cost-effective way to dissipate unwanted energy and correct for machine and floor leveling problems.

ANTI-VIBRATION LEVELING MOUNTS

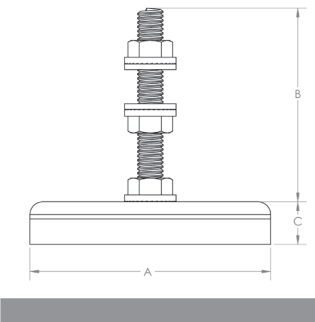

PART NUMBER	THREAD (UNC)	DIMENSIONS			DURO +/- 5	RATED LOAD (lbs)	NOTES
		A	B	C			
0510510-70-10	¼ - 20	2.00	1.875	0.75	70	75 - 185	
0510505-70-10	¼ - 20	2.25	1.875	0.75	70	115 - 285	
0510515-70-10	¼ - 20	2.50	1.875	0.62	70	195 - 485	
0510520-70-10	⅜ - 16	2.50	2.875	0.62	70	195 - 485	
0510530-70-10	⅜ - 16	3.50	2.875	0.88	70	370 - 925	
0510525-70-10	⅜ - 16	3.50	2.875	0.62	70	820 - 2070	



FAMILY Relationships built on mutual respect and teamwork

CUSTOMER PARTNERS Listen first – then collaborate to engineer the best solution

QUALITY Excellence – delivered across all platforms

INTEGRITY Adherence to a code of moral values and methods

SERVICE Striving to meet and exceed all expectations

